

Z-Line Standard Boltless Rack Shelving

RETAIN INSTRUCTIONS FOR FUTURE REFERENCE



GENERAL SAFETY INFORMATION

Some parts may have sharp edges. CARE must be taken when handling various pieces to avoid injury. For safety, wear a pair of work gloves when assembling or performing any maintenance on units.

LIMITED WARRANTY

Tennsco warrants goods purchased hereunder to be free of defects in materials and workmanship for a period of one (1) year from the date of shipment, hereunder. This warranty shall not apply in the event goods are damaged as a result of misuse, abuse, neglect, accident, improper application, modification or repair by persons not authorized by Seller, where goods are damaged during shipment, or where the date stamps on the goods have been defaced, modified or removed. UNLESS CONSIDERED UNENFORCEABLE OR UNLAWFUL UNDER APPLICABLE LAW:

- a. ALL IMPLIED WARRANTIES, INCLUDING BUT NOT LIMITED TO WARRANTIES OR MERCHANTABILITY AND FITNESS FOR A PARTICULAR PURPOSE ARE HEREBY EXCLUDED:
- b. BUYERS REMEDY, IF ANY, FOR ANY DEFECTIVE GOODS SHALL BE LIMITED TO A REFUND BY SELLER OR REPLACEMENT OF THE GOODS AT SELLER'S OPTION, AND SHALL IN NO EVENT INCLUDE DAMAGES OF ANY KIND, WHETHER INCIDENTAL, CONSEQUENTIAL OR OTHERWISE.

NO GOODS ACCEPTED FOR RETURN WITHOUT PRIOR APPROVAL. Seller shall have the right to inspect any goods claimed to be defective at Buyers place of business or require Buyer to return the goods to Seller for inspection on Seller's premises. Transportation charges covering returned goods will be borne by Seller only if such goods are proven to be defective, are covered by this warranty and are returned within the warranty period stated above.



PROUDLY MADE IN THE U.S.A.

Tennsco LLC., Dickson, TN 37056-1888 • (866) 446-8686

ASSEMBLY OF STANDARD BOLTLESS SHELVING

Tools Needed: A rubber mallet for seating the shelf supports into the uprights.

Two people are recommended for assembly. Approximate assembly time: 20-30 minutes per section.

1. The reference numbers used throughout this sheet refer to the illustration on the back cover. This is to help you to identify the various parts as they are mentioned.
2. Depending upon whether you ordered a single unit or an adder unit, you may have one or both of the styles of upright shown. A single unit will use EUR posts for all four uprights, as show below in Figure A. If you plan on installing an adder unit, you should build your starter unit with two ZTP posts on one end which will join with the adder as shown in Figure B.

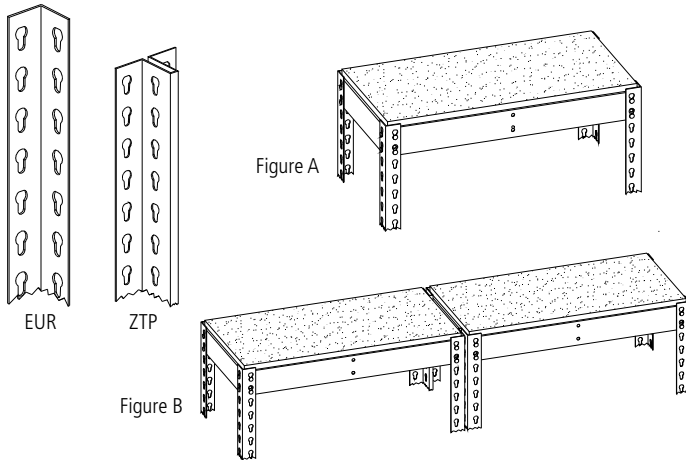

3. With the help from an associate, or using a wall for support, connect two EUR uprights (Ref. No. 1) using two front-to-back supports (Ref. No. 3), one at the top and one near the bottom (leaving the bottom-most keyhole slot empty). Be sure the front-to-back supports are fully seated in the keyhole slots as shown.

NOTE: Inset is shown from the opposite side (below).

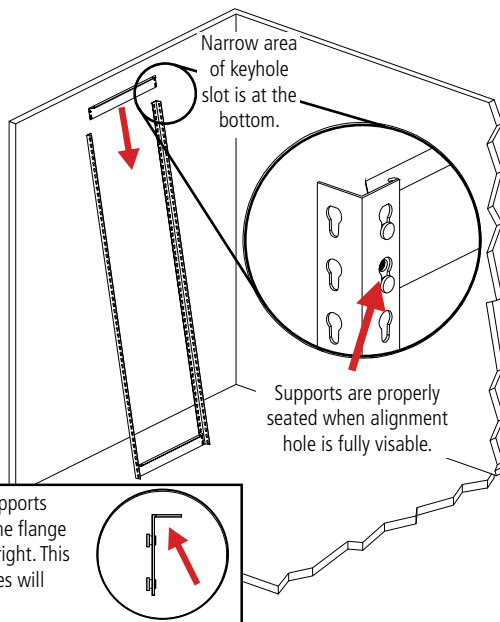

4. Place a third front-to-back support in the middle slots of the two uprights (at the level you want your third shelf to be). This forms one end of the shelving unit. Repeat steps 3 and 4 to construct a second set of unit ends.

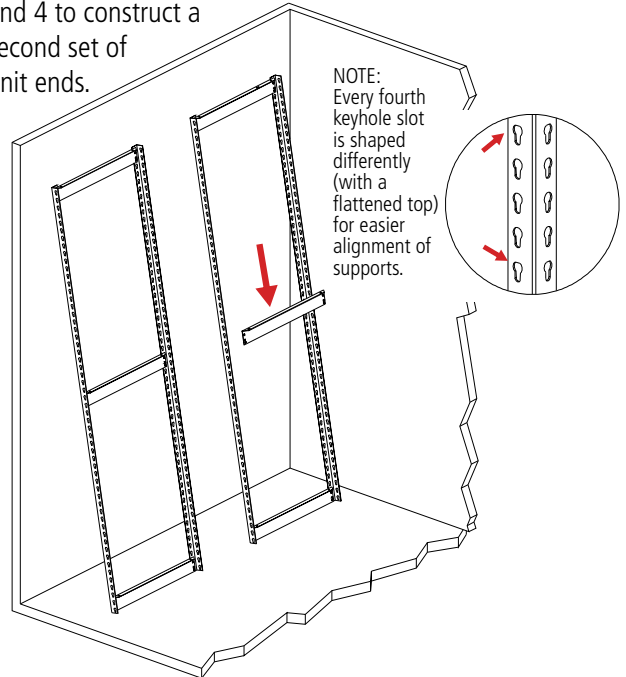

NOTE: If you are planning to install an adder unit, this second set of uprights should consist of ZTP uprights (Ref. No. 2) to act as an intermediate assembly. Carefully review step 2 to better understand.

5. With the help of an associate, connect the two unit ends with left-to-right shelf supports (Ref. No. 4). These should be placed with the flange up and at matching levels with the front-to-back supports, creating a flat surface on which to place decking.

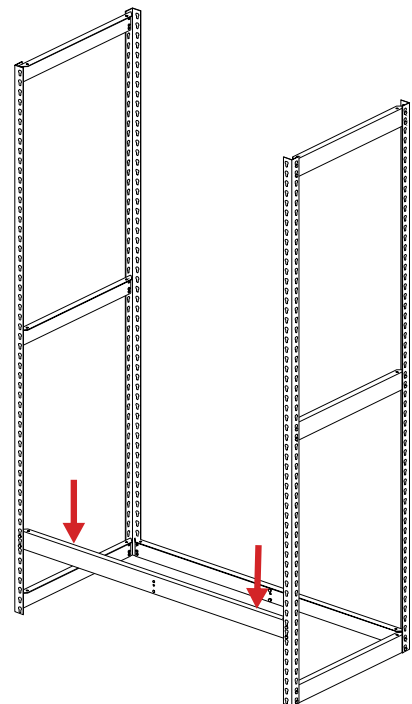

6. Attach the remaining shelf supports at the desired shelf levels, making sure that all shelf supports are completely seated in the upright slots.

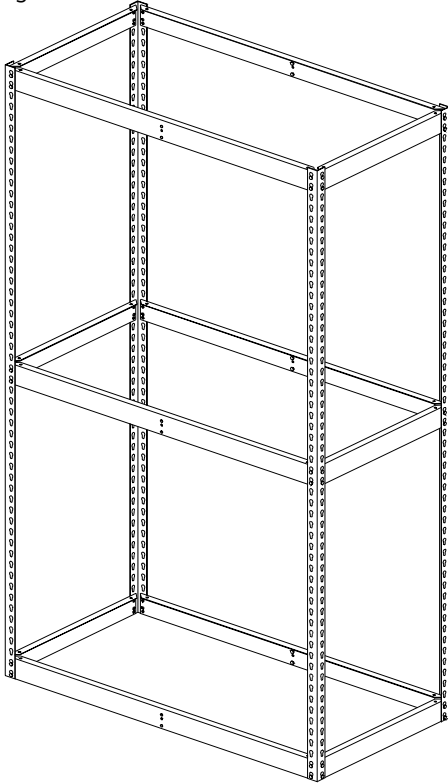

NOTE: If you have purchased additional shelf levels, the shelf supports for the extra levels may also be inserted at this time.

7. Attach the shelf reinforcements (Ref. No. 5) at each level by sliding them onto the rivets until centered. Tap down on the reinforcements until they are seated firmly.

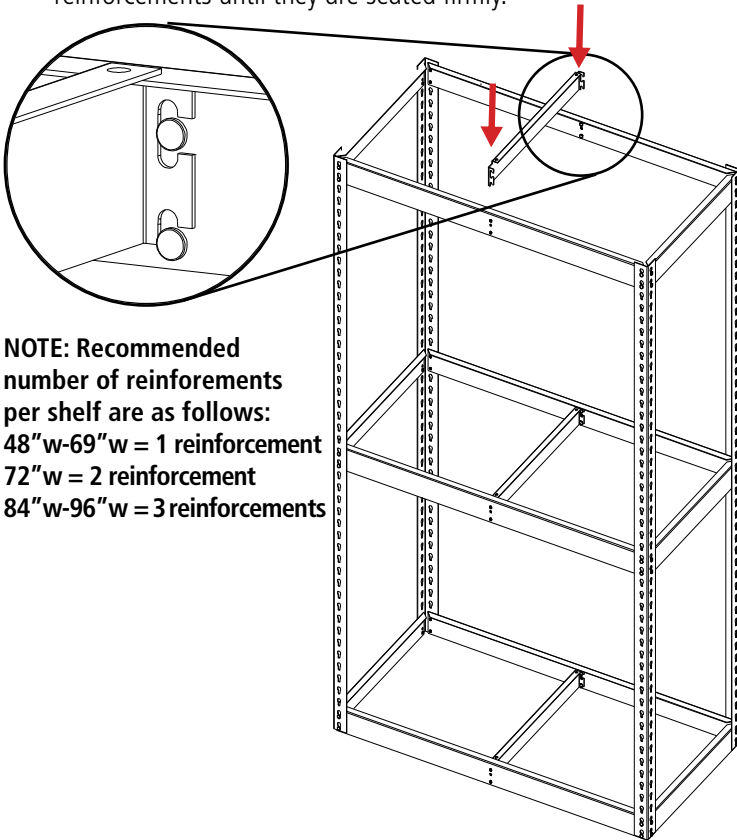

NOTE: Recommended number of reinforcements per shelf are as follows:
48" w-69" w = 1 reinforcement
72" w = 2 reinforcement
84" w-96" w = 3 reinforcements

8. If particle board decking (Ref. No. 6) was ordered, place the decking on each shelving level. The decking should fit flush inside the shelf supports. If you have purchased a single unit, your shelving unit is now complete. For adder units, see step 9.

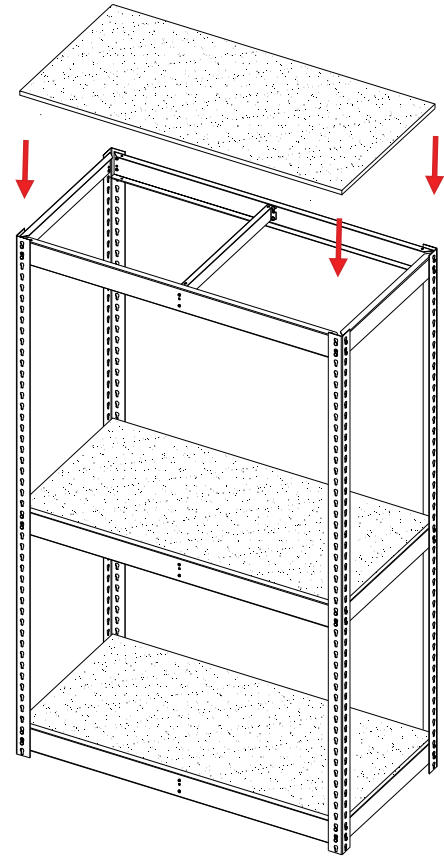

9. If joining more than one unit together, your original unit should have been assembled with ZTP uprights on one end, as described in step 4. Simply continue adding shelf supports and uprights to complete your additional units.

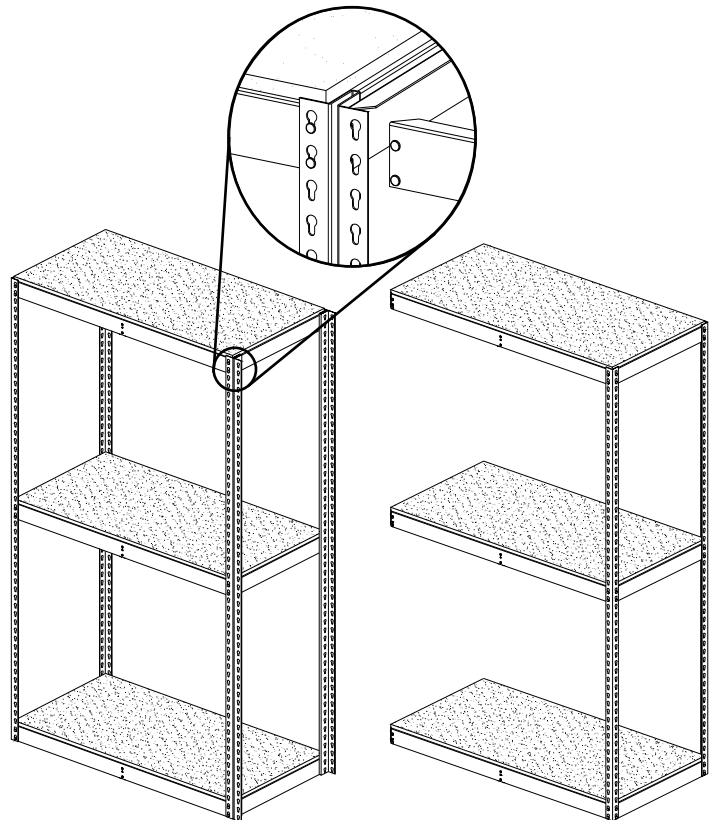

REPLACEMENT PARTS

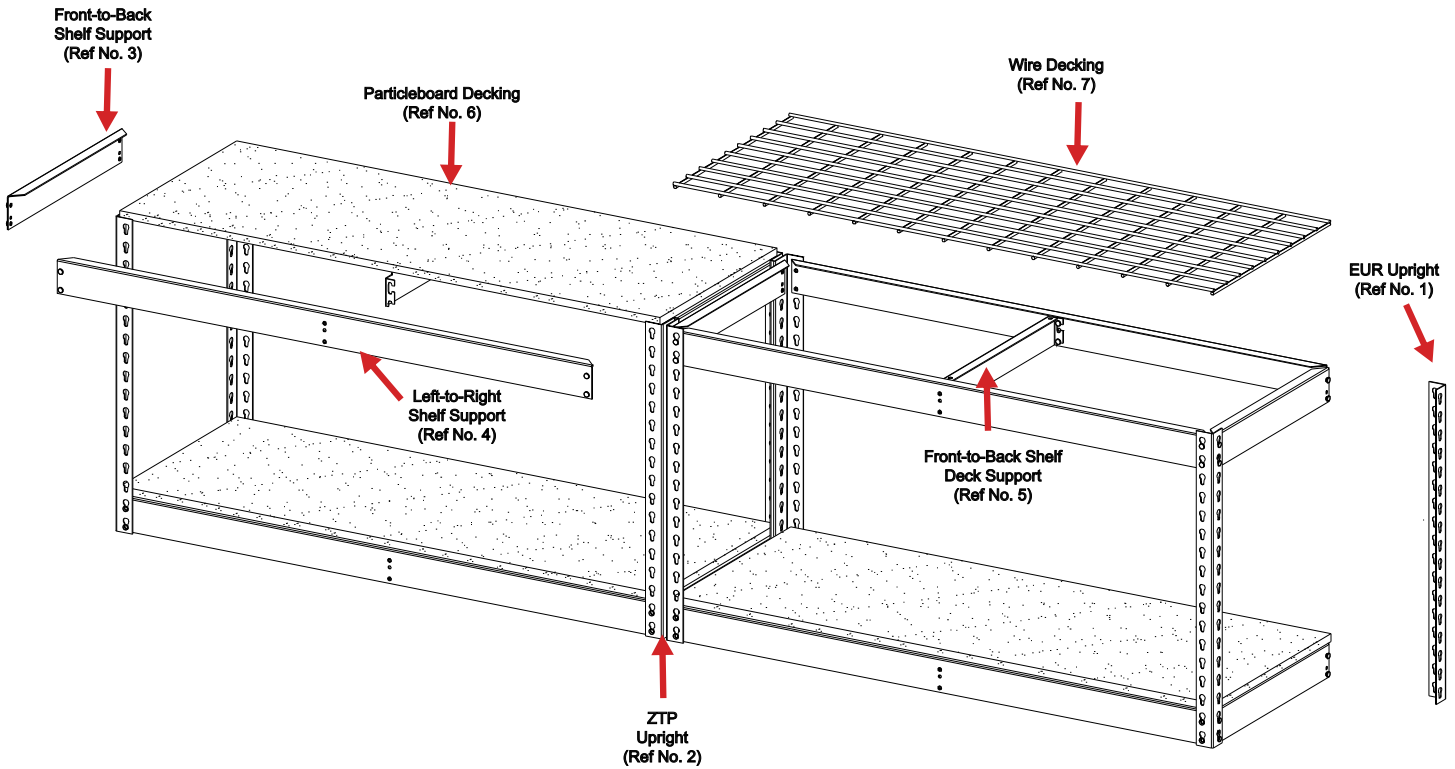

REF. NO.	DESCRIPTION	PART NO.**	QTY.
1	High Capacity Post (single or starter units only)	EUR-hh	4
2	"T" Post (adder units only)	ZTP-hh	2
3	Front-to-Back Shelf Support		
	12" to 32" Shelf Depth	LRA-dd	6
	36" to 96" Shelf Depth	LRA-ddG	6
4	Left-to-Right Channel Beam	LRA-ww	6
5	Front-to-Back Shelf Deck Support		
	42" to 69" Shelf Width	SDS-dd	1
	72" Shelf Width	SDS-dd	2
	84" to 96" Shelf Width	SDS-dd	3
6	Optional Particleboard Decking	PB-wwdd	3
7	Optional Wiring Decking	ZWD-wwdd	3

**Where the suffix "ww", "dd" or "hh" is used in the part number, the width (ww), depth (dd) or height (hh) is substituted in the part number. For example, for an 84" high Angle Post, the part number would be EUR-84.

Quantities apply to the basic 3-shelf unit only. If you have ordered additional shelf levels, quantities will vary accordingly.

NOTE: Additional hardware may be included for replacement purposes.

Tennsco makes every effort to ensure that all units ship complete with all parts and arrive undamaged. However, should your unit contain missing or damaged parts, please contact your purchase location.